

REASSEMBLY

1. BEARING POSITION

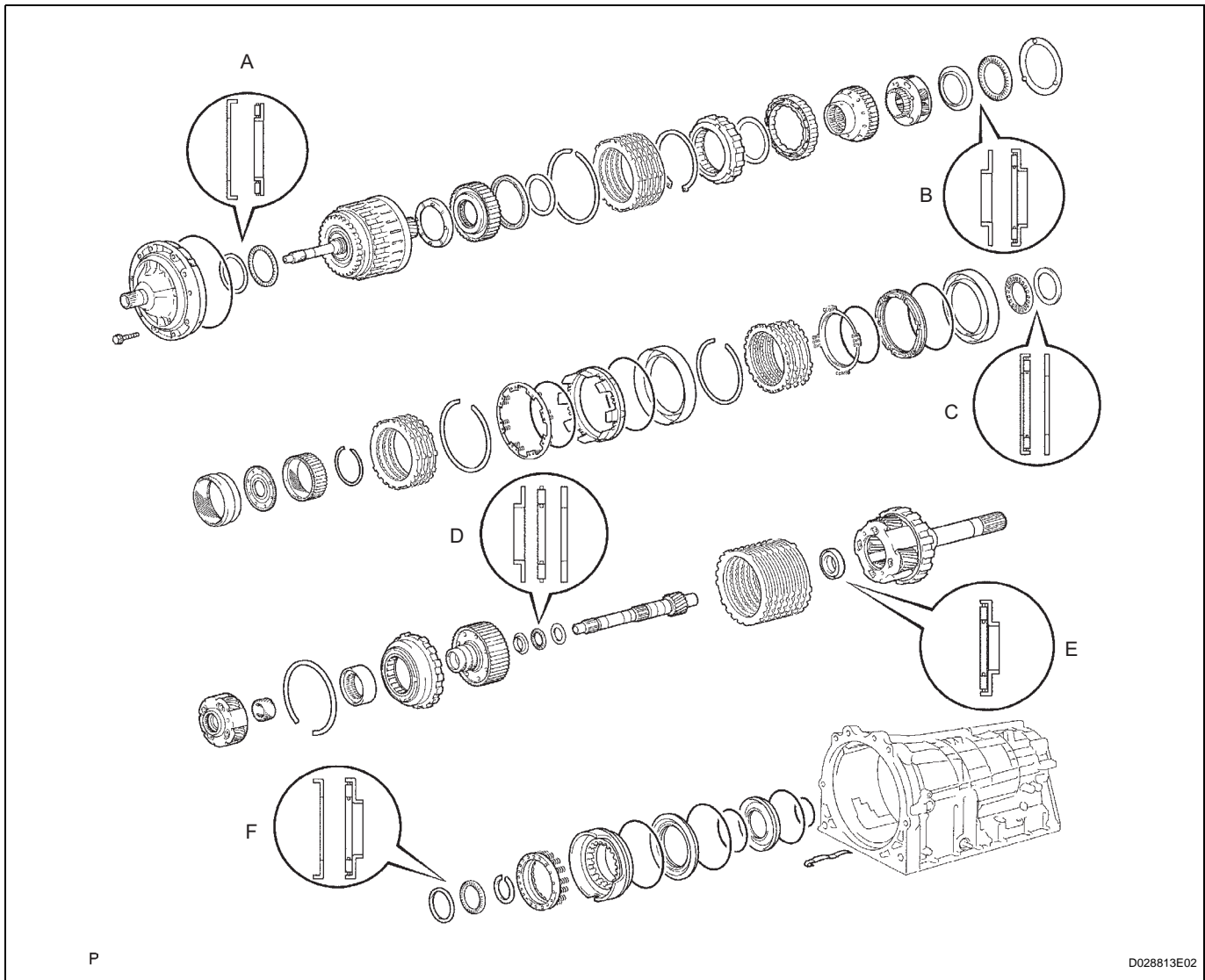

AT

Bearing diameter

Mark	Front Race Diameter Inside / Outside	Thrust Bearing Diameter Inside / Outside	Rear Race Diameter Inside / Outside
A	73.6 mm (2.898 in.) / 102.0 mm (4.016 in.)	71.9 mm (2.831 in.) / 85.6 mm (3.370 in.)	-
B	38.0 mm (1.496 in.) / 57.0 mm (2.244 in.)	43.4 mm (1.709 in.) / 58.3 mm (2.295 in.)	-
C	-	55.7 mm (2.193 in.) / 76.4 mm (3.008 in.)	53.7 mm (2.114 in.) / 74.0 mm (2.913 in.)
D	33.4 mm (1.315 in.) / 49.0 mm (1.929 in.)	32.1 mm (1.264 in.) / 49.35 mm (1.943 in.)	32.1 mm (1.2649 in.) / 49.0 mm (1.929 in.)
E	-	21.5 mm (0.847 in.) / 40.8 mm (1.606 in.)	-
F	48.5 mm (1.909 in.) / 62.7 mm (2.469 in.)	45.9 mm (1.807 in.) / 64.0 mm (2.520 in.)	-

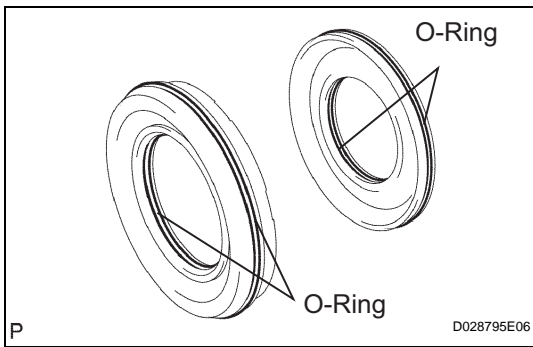

2. INSTALL NO. 4 BRAKE PISTON

- (a) Coat 2 new O-rings with ATF, and install them onto the brake reaction sleeve.
- (b) Coat 2 new O-rings with ATF, and install them onto the No. 4 brake piston.
- (c) Install the No. 4 brake piston onto the reaction sleeve.

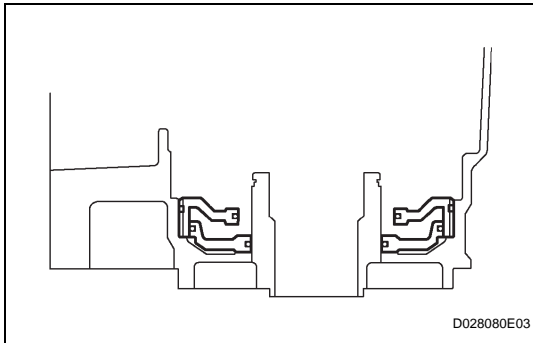

3. INSTALL BRAKE REACTION SLEEVE

- (a) With the No. 4 brake piston underneath (the rear side), install the brake reaction sleeve and No. 4 brake piston onto the transmission case.

NOTICE:

Be careful not to damage the O-rings.

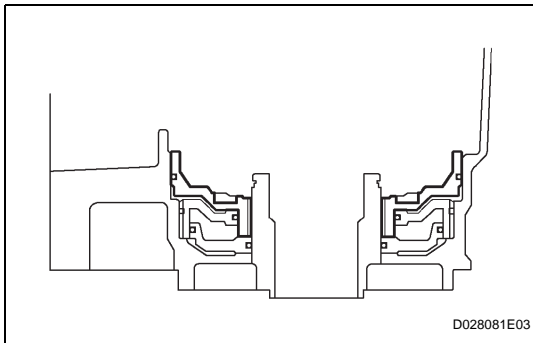

4. INSTALL 1ST AND REVERSE BRAKE PISTON

- (a) Coat a new O-ring with ATF.
- (b) Install the O-ring onto the 1st and reverse brake piston.
- (c) With the spring seat of the piston facing upward (the front side), place the piston in the transmission case.

NOTICE:

Be careful not to damage the O-ring.

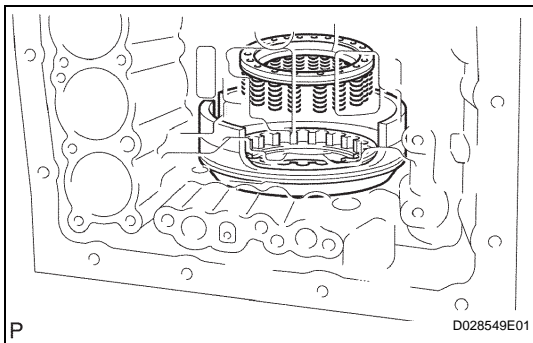

- (d) Place the 1st and reverse brake return spring onto the 1st and reverse brake piston.

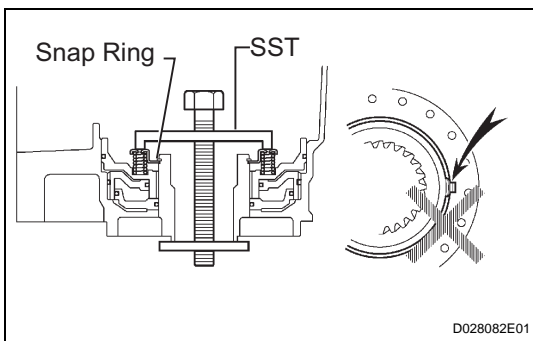

5. INSTALL 1ST AND REVERSE BRAKE RETURN SPRING SUB-ASSEMBLY

- (a) Place SST on the spring retainer, and compress the return spring.

SST 09350-30020 (09350-07050)

- (b) Using SST, install the snap ring.

SST 09350-30020 (09350-07070)

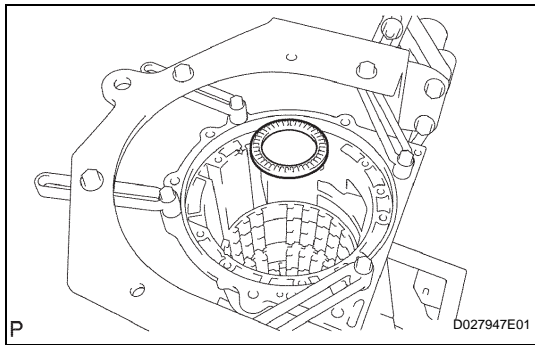

6. INSTALL REAR PLANETARY GEAR ASSEMBLY

(a) Install the thrust needle roller bearing.

Thrust needle roller bearing diameter

Item	Inside	Outside
Thrust needle roller bearing	45.9 mm (1.807 in.)	64.0 mm (2.520 in.)

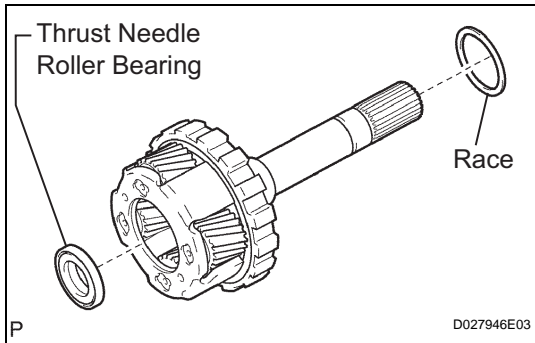

(b) Install the thrust needle roller bearing.

(c) Coat the No. 9 thrust bearing race with petroleum jelly, and install it onto the rear planetary gear.

Bearing and race diameter

Item	Inside	Outside
Bearing	21.5 mm (0.847 in.)	40.8 mm (1.606 in.)
Race	48.5 mm (1.909 in.)	62.7 mm (2.469 in.)

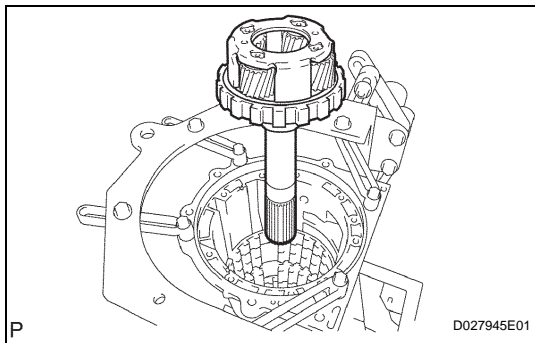

(d) Install the rear planetary gear assembly.

AT

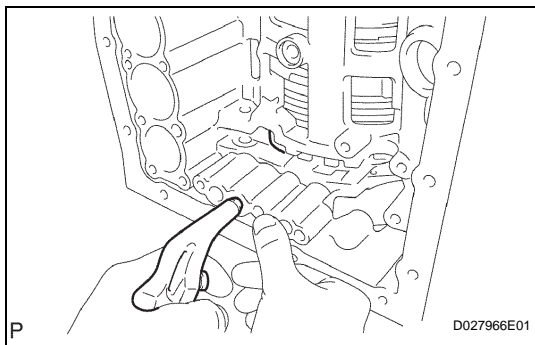

7. INSPECT PACK CLEARANCE OF FIRST AND REVERSE BRAKE

(a) Make sure the 1st and reverse brake pistons move smoothly when applying and releasing the compressed air into the transmission case.

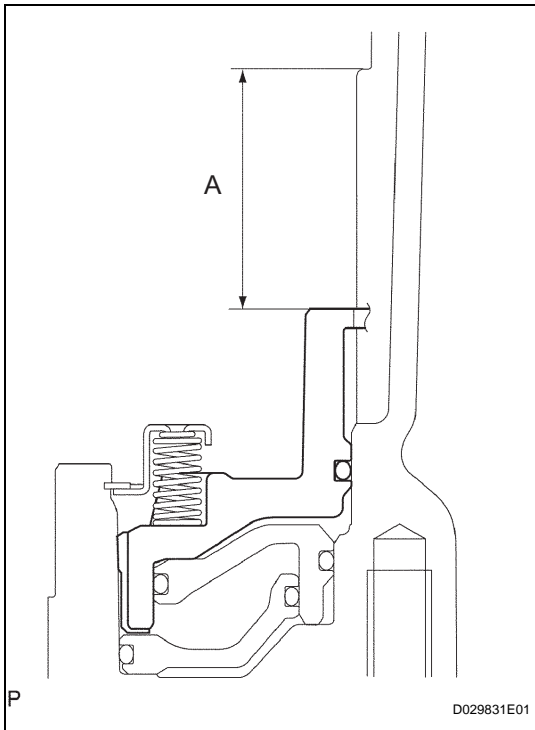

- (b) Using vernier calipers, measure the level difference (length A) between the upper surface of the 1st and reverse brake piston and the hitting surface of the No. 4 brake flange at both ends across a diameter, and calculate the average.

NOTICE:

The 1st and reverse brake piston must be installed tightly to the end face of the transmission case.

HINT:

Length A = 36.35 to 37.09 mm (1.431 to 1.460 in.)

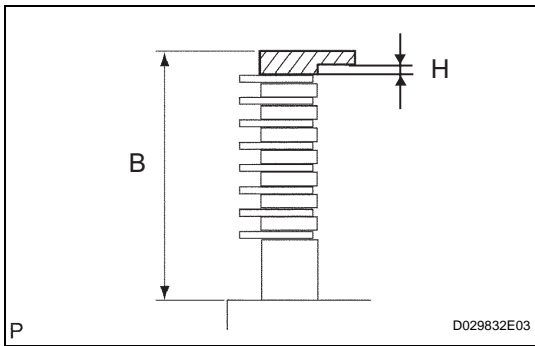

- (c) Using vernier calipers, measure the thickness (length B) of the 2 brake flanges, the 7 No. 4 brake plates and the 8 No. 4 brake discs altogether at both ends across a diameter, and calculate the average.

HINT:

Pack clearance = Length A - Length B - 0.25 mm - 1.8 mm

Length B = 36.04 to 37.14 mm (1.419 to 1.462 in.)

Pack clearance:

0.8 to 1.1 mm (0.031 to 0.043 in.)

- (d) If the pack clearance is outside the standard, select and install a brake flange that makes the pack clearance within the standard.

H thickness

No.	Thickness	No.	Thickness
0	0 mm (0 in.)	8	0.8 mm (0.031 in.)
2	0.2 mm (0.008 in.)	10	1.0 mm (0.039 in.)
4	0.4 mm (0.016 in.)	12	1.2 mm (0.047 in.)
6	0.6 mm (0.024 in.)	14	1.4 mm (0.055 in.)

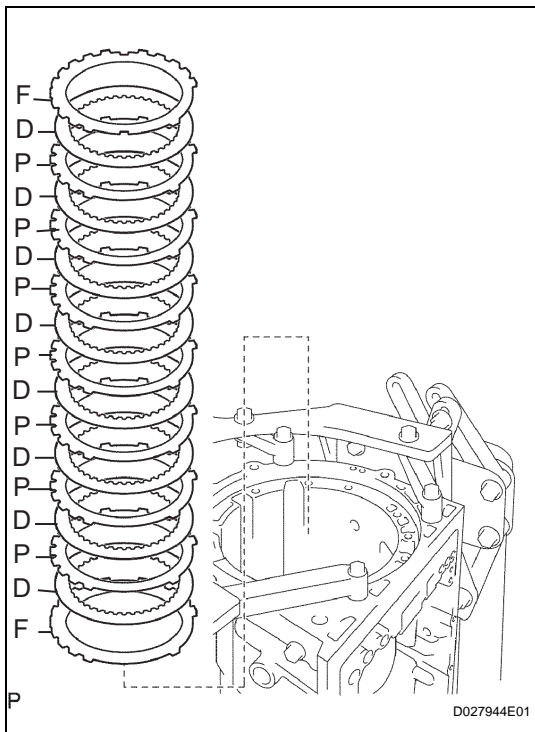

8. INSTALL NO. 4 BRAKE DISC

(a) Install the 7 plates, the 8 discs and the 2 flanges.

Install in order:

F - D - P - D - P - D - P - D - P - D - P - D - P - D - P - D - P

HINT:

P = Plate, D = Disc, F = Flange

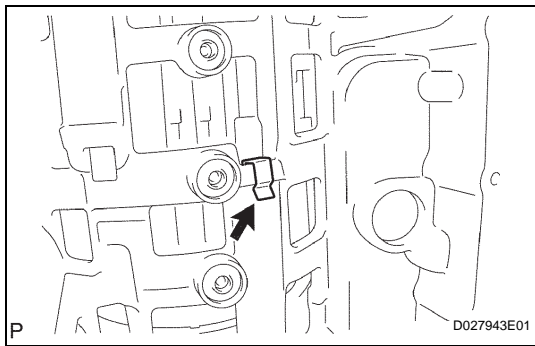

9. INSTALL BRAKE PLATE STOPPER SPRING

(a) Install the brake stopper spring.

AT

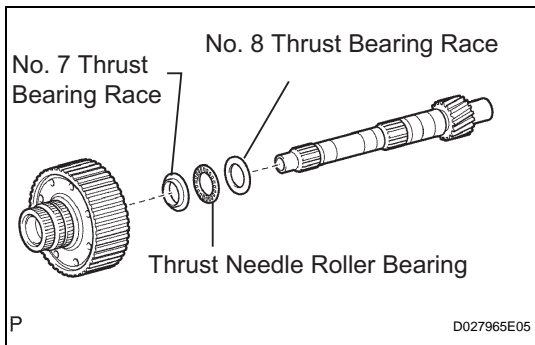

10. INSTALL REAR PLANETARY RING GEAR FLANGE SUB-ASSEMBLY

(a) Install the No. 8 thrust bearing race, thrust needle roller bearing, No. 7 thrust bearing race and planetary ring gear flange onto the intermediate shaft.

Bearing and race diameter

Item	Inside	Outside
No. 7 thrust bearing race	33.4 mm (1.315 in.)	49.0 mm (1.929 in.)
Thrust needle roller bearing	32.1 mm (1.264 in.)	49.35 mm (1.943 in.)
No. 8 thrust bearing race	32.1 mm (1.264 in.)	49.0 mm (1.929 in.)

(b) Install the rear planetary ring gear flange onto the intermediate shaft.

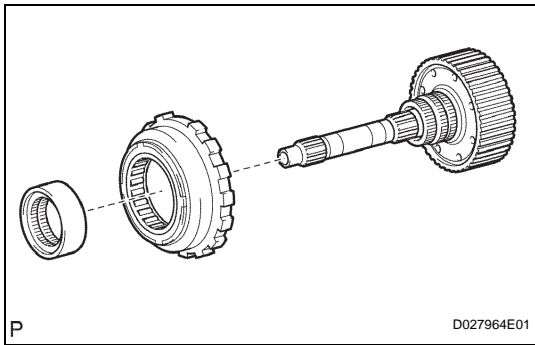

11. INSTALL NO. 3 1-WAY CLUTCH ASSEMBLY

- (a) Install the No. 3 1-way clutch assembly and 1-way clutch inner race onto the intermediate shaft.

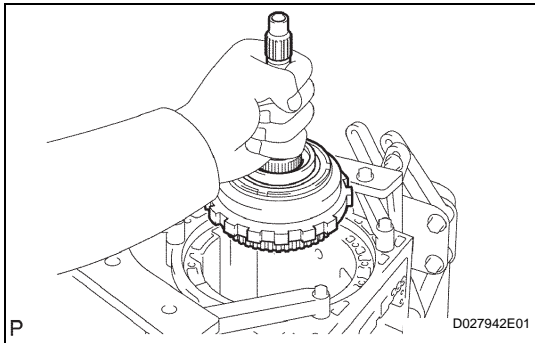

12. INSTALL INTERMEDIATE SHAFT

- (a) Install the intermediate shaft with the No. 3 1-way clutch assembly into the case.

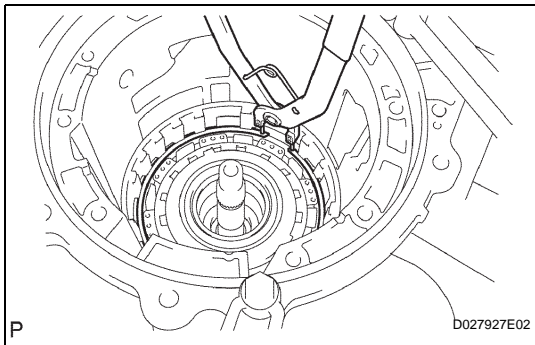

- (b) Using SST, install the snap ring.
SST 09350-30020 (09350-07050, 09350-07060)

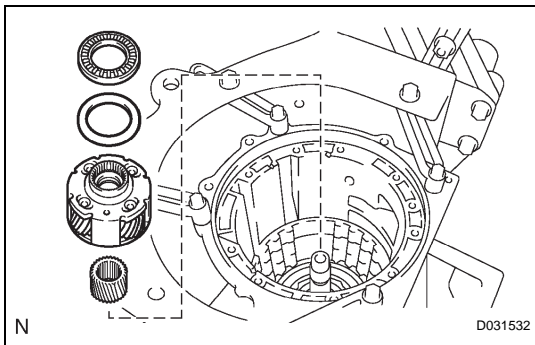

13. INSTALL CENTER PLANETARY GEAR ASSEMBLY

- (a) Install the center planetary gear assembly and planetary sun gear into the case.
- (b) Coat the No. 4 thrust bearing race and thrust needle roller bearing with petroleum jelly, and install them onto the center planetary ring gear.

Race and Bearing diameter

Item	Inside	Outside
Race	53.7 mm (2.114 in.)	74.0 m (2.913 in.)
Bearing	55.7 mm (2.192 in.)	76.4 mm (3.008 in.)

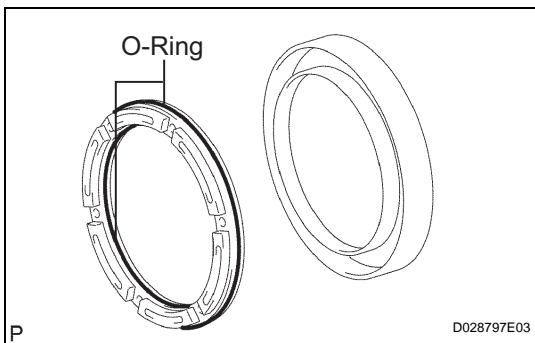

14. INSTALL NO. 2 BRAKE PISTON

- (a) Coat 2 new O-rings with ATF, and install them onto the No. 2 brake piston.
- (b) Be careful not to damage the O-rings. Press the No. 2 brake piston into the No. 2 brake cylinder with both hands.
- (c) Install the No. 2 brake piston onto the case.

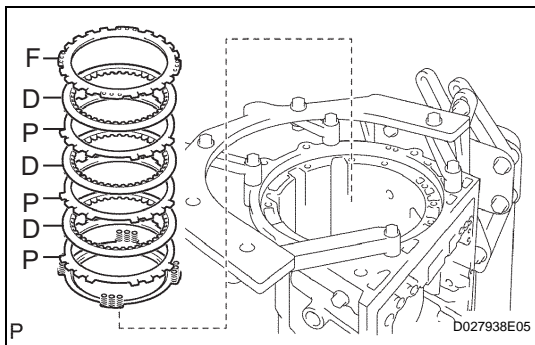

15. INSTALL NO. 2 BRAKE DISC

- (a) Install flange, 3 plates, 3 discs and No. 2 brake piston return spring.

Install in order:

F - D - P - D - P - D - P

HINT:

P = Plate, D = Disc, F = Flange

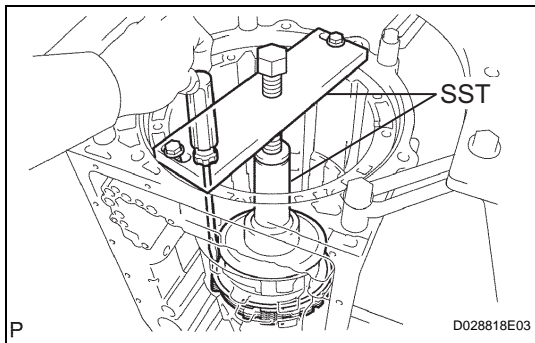

- (b) Using SST and press, install the No. 2 brake spring snap ring.

SST 09351-40010

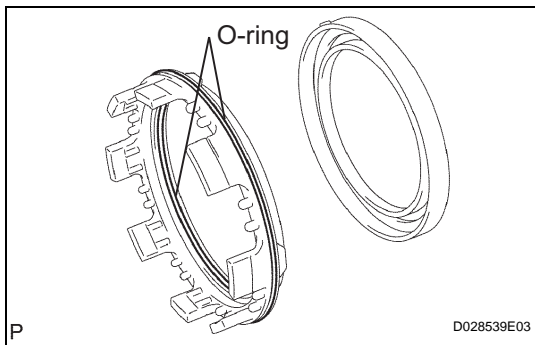

16. INSTALL NO. 1 BRAKE PISTON

- (a) Coat 2 new O-rings with ATF, and install them onto the No. 1 brake piston.
- (b) Be careful not to damage the O-rings. Press the No. 1 brake piston into the No. 1 brake cylinder with both hands.

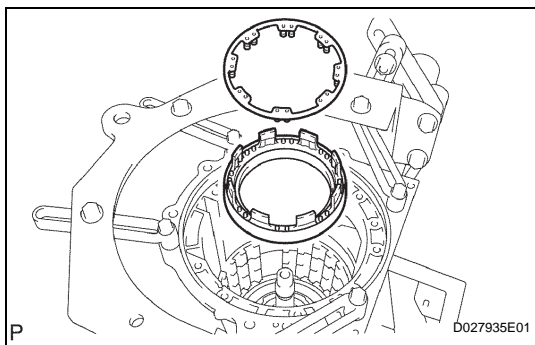

17. INSTALL BRAKE PISTON RETURN SPRING SUB-ASSEMBLY

- (a) Install the brake piston return spring and the No. 1 brake piston with the No. 1 brake cylinder into the transmission case.

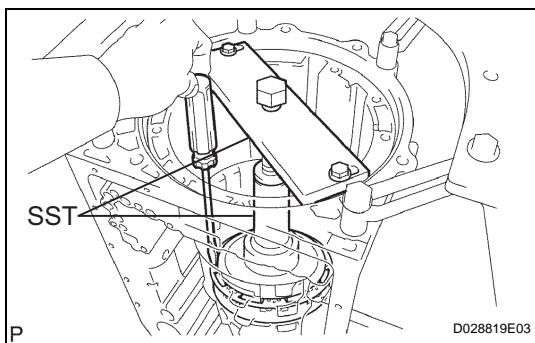

18. INSTALL BRAKE PISTON RETURN SPRING SNAP RING

- (a) Using SST and a press, install the brake piston return spring snap ring.

SST 09351-40010

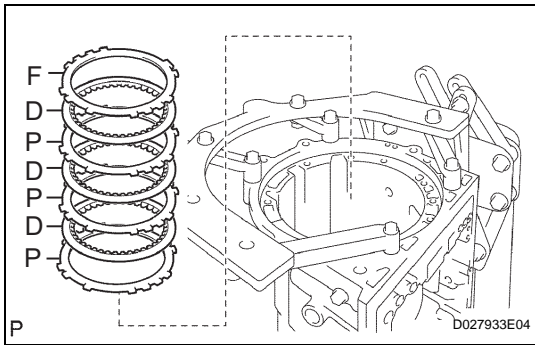

19. INSTALL NO. 1 BRAKE DISC

(a) Install the 3 plates, 3 discs and flange.

Install in order:

F - D - P - D - P - D - P

HINT:

P = Plate, D = Disc, F = Flange

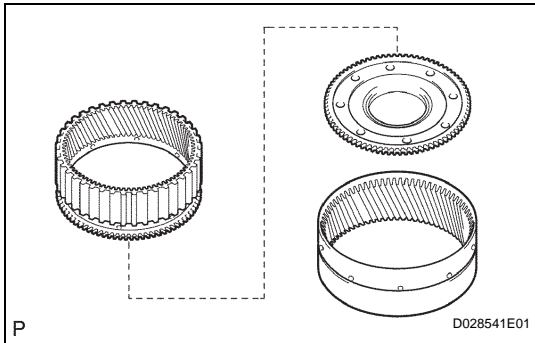

20. INSTALL CENTER PLANETARY RING GEAR

(a) Install the center planetary ring gear and front planetary ring gear flange into the front planetary ring gear.

(b) Using a screwdriver, install the snap ring.

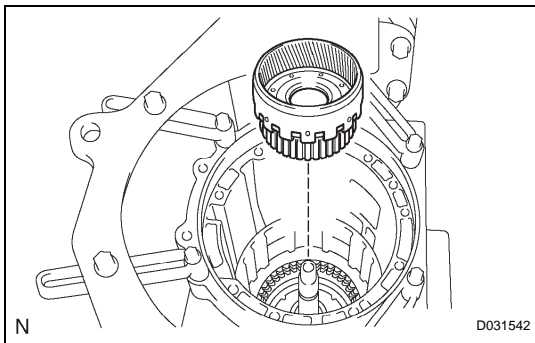
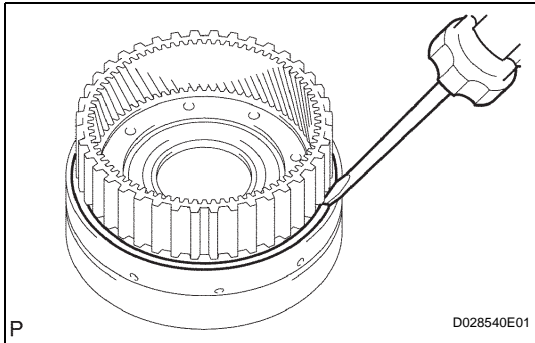

21. INSTALL FRONT PLANETARY RING GEAR

(a) Install the front planetary ring gear into the case.

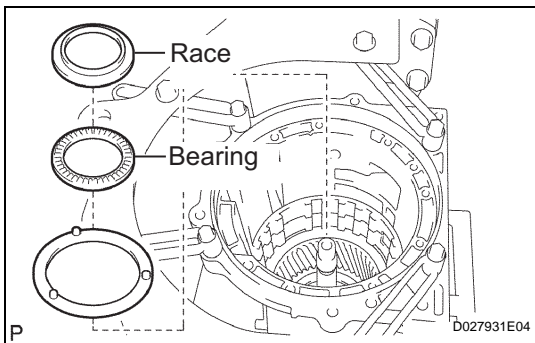

22. INSTALL FRONT PLANETARY GEAR ASSEMBLY

(a) Install the thrust needle roller bearing and the No. 2 planetary carrier thrust washer.

(b) Coat the No. 3 thrust bearing race with petroleum jelly, and install it onto the front planetary ring gear.

Thrust needle roller bearing and race diameter

Item	Inside	Outside
Thrust needle roller bearing	43.4 mm (1.709 in.)	58.3 mm (2.295 in.)
Race	38.0 mm (1.496 in.)	57.0 mm (2.244 in.)

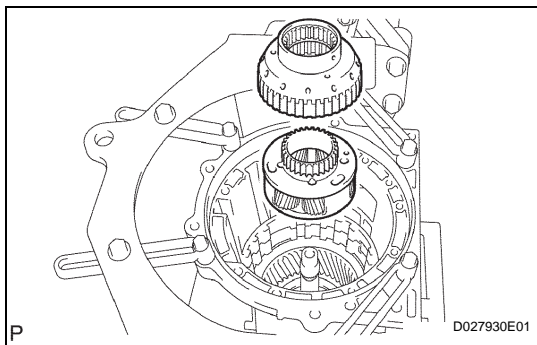

- (c) Install the front planetary gear assembly and 1-way clutch inner race into the case.

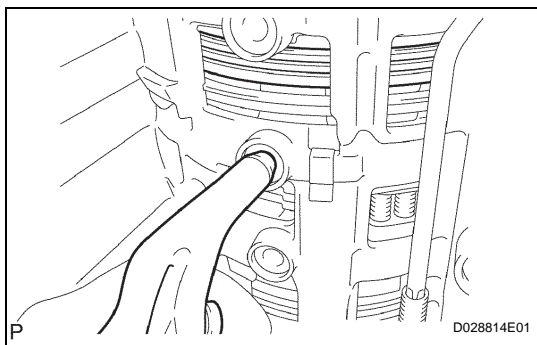

23. INSPECT NO. 1 PISTON STROKE OF BRAKE PISTON

- (a) Make sure the No. 1 brake piston moves smoothly when applying and releasing the compressed air into the transmission case.

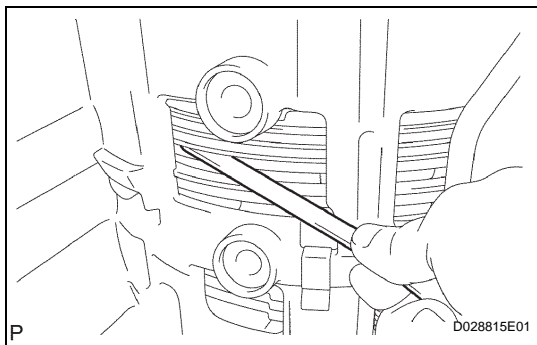

- (b) Using a feeler gauge, measure the B3 brake pack clearance between the snap ring and flange.

Piston stroke:

0.42 to 0.72 mm (0.017 to 0.028 in.)

If the piston stroke is outside the specification, parts may have been assembled incorrectly.

Perform the reassembly again.

If the piston stroke is still outside the specification, select another flange.

HINT:

There are 4 different thicknesses for the flange.

Flange thickness

No.	Thickness	No.	Thickness
0	2.0 mm (0.079 in.)	2	2.4 mm (0.094 in.)
1	2.2 mm (0.087 in.)	3	2.6 mm (0.102 in.)

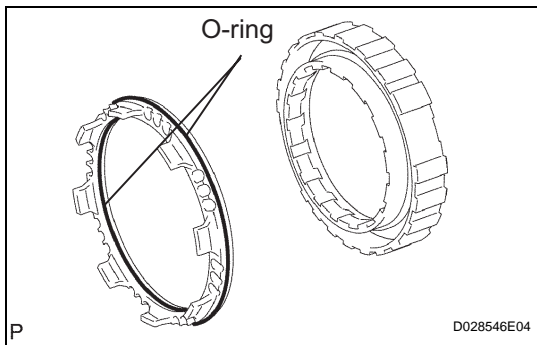

24. INSTALL 2ND BRAKE PISTON

- (a) Coat 2 new O-rings with ATF, and install them onto the 2nd brake piston.
- (b) Be careful not to damage the O-rings. Press the 2nd brake cylinder into the 2nd brake piston with both hands.

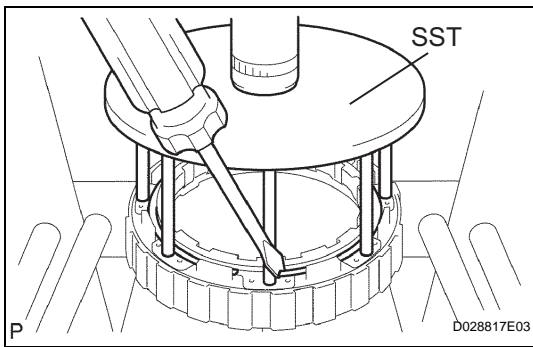

- (c) Using SST and press, install the snap ring.

SST 09351-40010

NOTICE:

Make sure that the end gap of the snap ring is not aligned with the spring retainer claw.

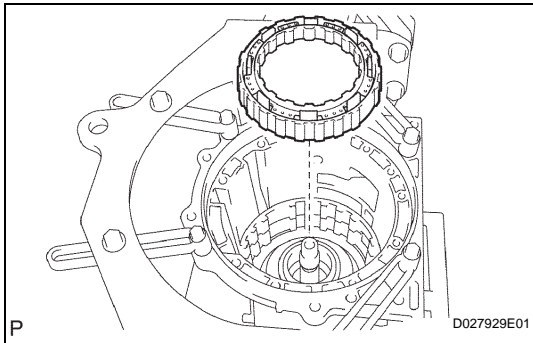

25. INSTALL 2ND BRAKE CYLINDER

- (a) Install the 2nd brake cylinder into the case.

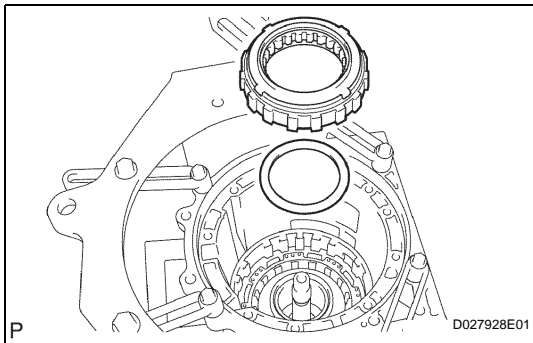

26. INSTALL 1-WAY CLUTCH ASSEMBLY

- (a) Install the 1-way clutch assembly and the thrust washer into the case.

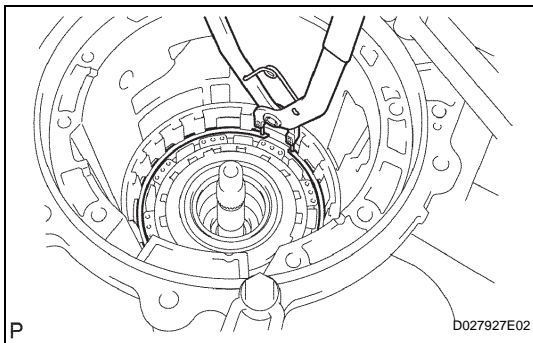

27. INSTALL 2ND BRAKE PISTON HOLE SNAP RING

- (a) Using SST, install the snap ring.
SST 09350-30020 (09350-07060)

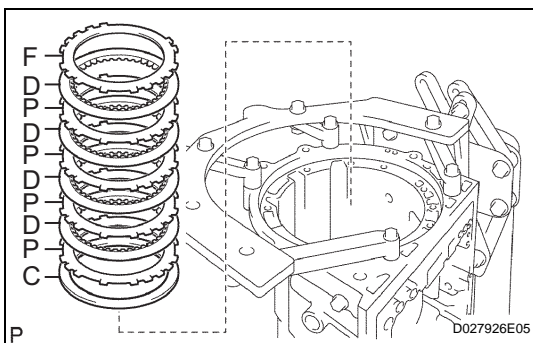

28. INSTALL NO. 3 BRAKE DISC

- (a) Install the flange, the 4 discs, the 4 plates and the cushion plate into the case.

Install in order:

F - D - P - D - P - D - P - D - P - C

HINT:

P = Plate, D = Disc, F = Flange C = Cushion

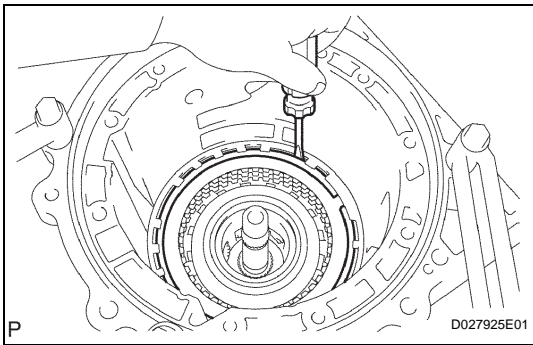

29. INSTALL NO. 3 BRAKE SNAP RING

- (a) Using a screwdriver, install the snap ring.

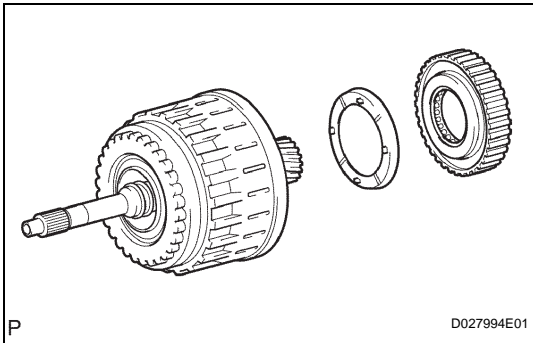

30. INSTALL NO. 2 1-WAY CLUTCH ASSEMBLY

- (a) Install the No. 2 1-way clutch assembly and No. 2 clutch drum thrust washer onto the clutch drum and input shaft.

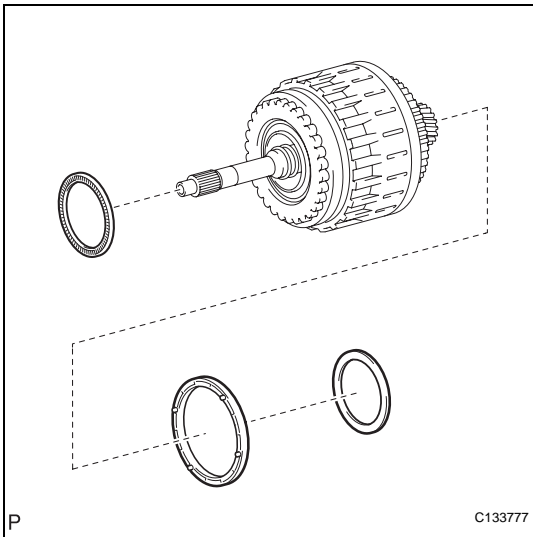

31. INSTALL CLUTCH DRUM AND INPUT SHAFT ASSEMBLY

- (a) Install the thrust needle roller bearing.
- (b) Coat the race with petroleum jelly and install it onto the clutch drum thrust washer.

Thrust needle roller bearing and diameter

Item	Inside	Outside
Thrust needle roller bearing	71.9 mm (2.831 in.)	85.6 mm (3.370 in.)
Race	73.6 mm (2.898 in.)	102.0 mm (4.016 in.)

- (c) Install the clutch drum thrust washer and race onto the clutch drum and input shaft assembly.

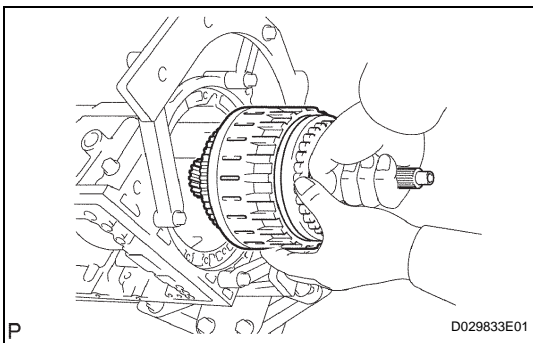

- (d) Install the input shaft sub-assembly with the direct and reverse multiple disc assembly onto the transmission case.

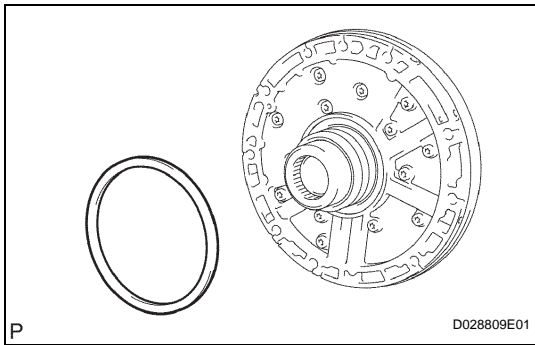

32. INSTALL OIL PUMP ASSEMBLY

- (a) Install the No. 1 thrust bearing race onto the front oil pump.

No. 1 Thrust bearing race diameter

Item	Inside	Outside
Race	74.2 mm (2.921 in.)	87.74 mm (3.454 in.)

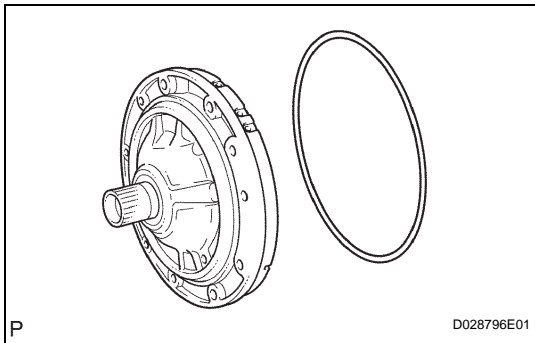

- (b) Coat a new O-ring with ATF, and install it onto the oil pump assembly.
- (c) Place the oil pump through the input shaft, and align the bolt holes in the oil pump assembly with the transmission case.
- (d) Hold the input shaft, and lightly press the oil pump body to slide the oil seal rings into the overdrive direct clutch drum.

NOTICE:

Do not push on the oil pump strongly, as the oil seal ring will stick to the direct clutch drum.

- (e) Install the 10 bolts.
Torque: 21 N*m (214 kgf*cm, 15 ft.*lbf)

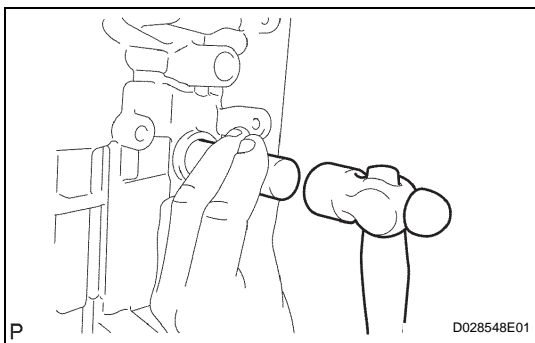
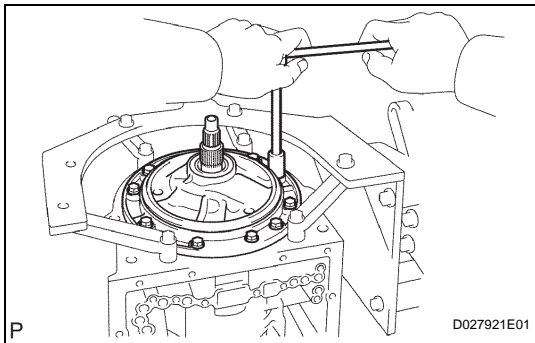

33. INSTALL MANUAL VALVE LEVER SHAFT OIL SEAL

- (a) Using SST, drive in 2 new oil seals.
SST 09350-30020 (09350-07110)
- (b) Coat the oil seal lips with MP grease.

34. INSPECT INDIVIDUAL PISTON OPERATION INSPECTION (See page AT-217)

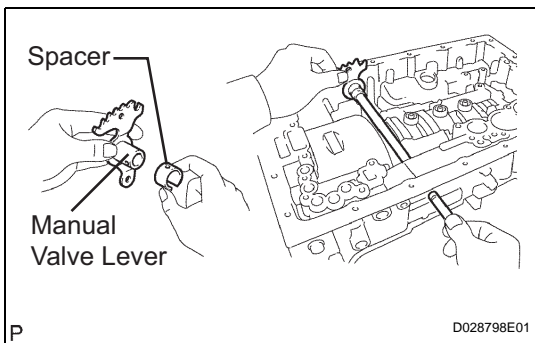

35. INSTALL MANUAL VALVE LEVER SUB-ASSEMBLY

- (a) Install a new spacer onto the manual valve lever.
- (b) Install the manual valve lever shaft onto the transmission case through the manual valve lever.

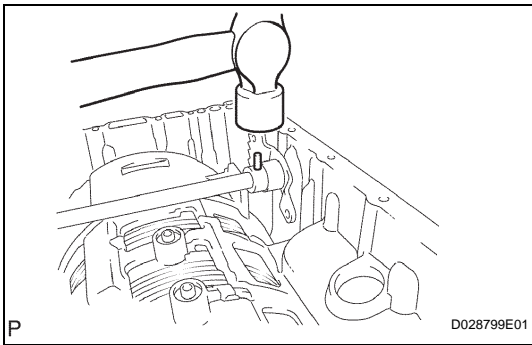

(c) Using a hammer, tap in a new spring pin.

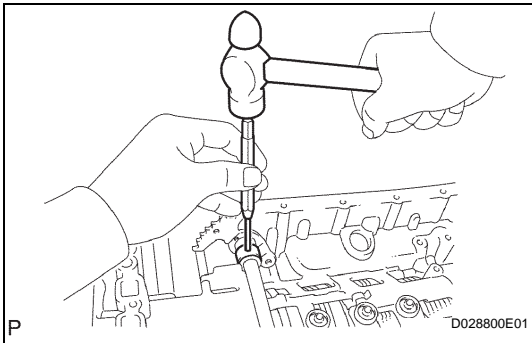

(d) Align the manual valve lever indentation with the spacer hole, and stake them together with a punch.

(e) Make sure the shaft rotates smoothly.

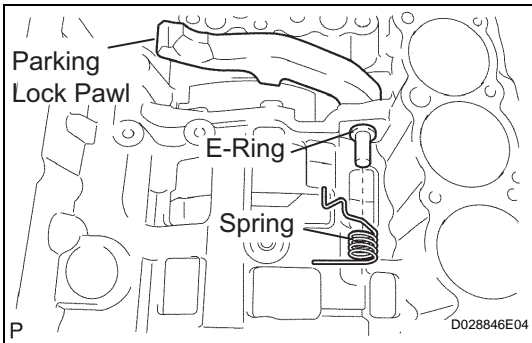

36. INSTALL PARKING LOCK PAWL SHAFT

(a) Install the E-ring onto the shaft.

(b) Install the parking lock pawl, shaft and spring.

AT

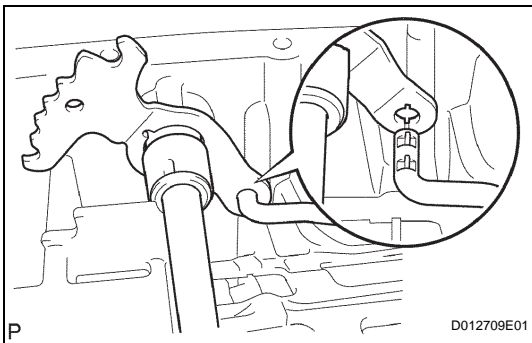

37. INSTALL PARKING LOCK ROD SUB-ASSEMBLY

(a) Connect the parking lock rod to the manual valve lever.

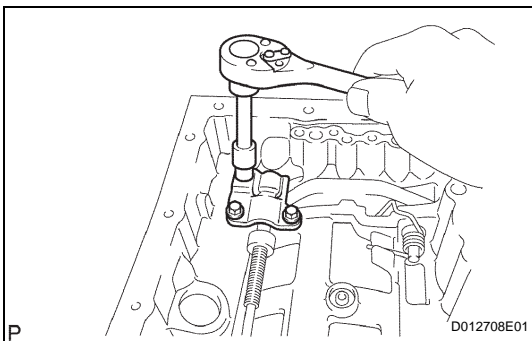

38. INSTALL PARKING LOCK PAWL BRACKET

(a) Place the parking lock pawl bracket onto the transmission case and tighten the 3 bolts.

Torque: 7.4 N*m (75 kgf*cm, 65 in.*lbf)

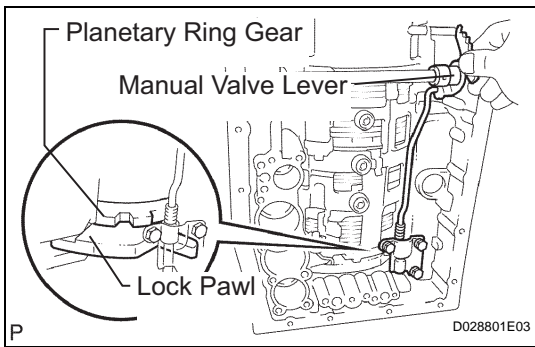

- (b) Shift the manual valve lever to the P position, and confirm that the planetary ring gear is correctly locked up by the lock pawl.

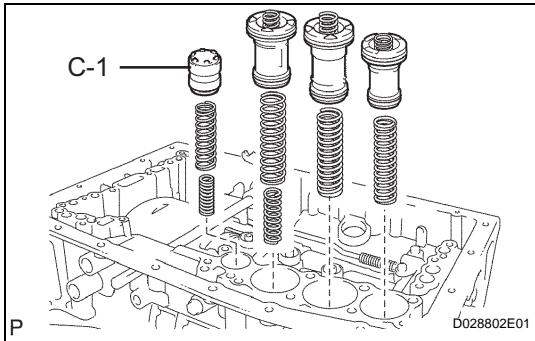

39. INSTALL C-1 ACCUMULATOR VALVE

- (a) Coat a new O-ring with ATF, and install it onto the piston.

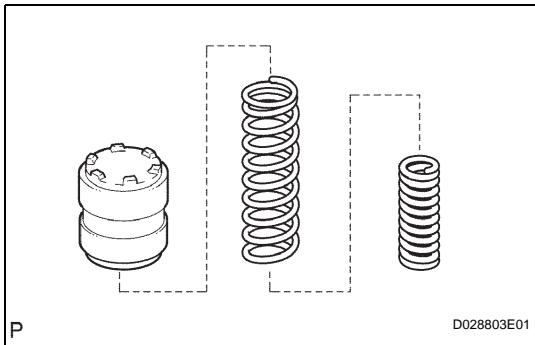

- (b) Install the 2 springs and accumulator valve into the hole.

Accumulator spring

Spring	Free length Outer diameter	Color
C-1 Inner	30.40 mm (1.197 in.) 11.40 mm (0.449 in.)	Pink
C-1 Outer	48.76 mm (1.920 in.) 16.60 mm (0.654 in.)	Light green

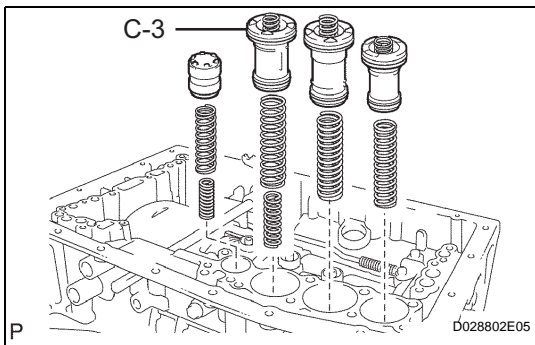

40. INSTALL C-3 ACCUMULATOR PISTON

- (a) Coat a new O-ring with ATF, and install it onto the piston.

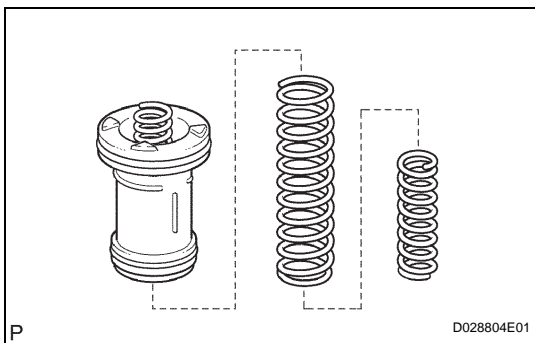

- (b) Install the 2 springs and accumulator piston into the hole.

Accumulator spring

Spring	Free length Outer diameter	Color
C-3 Inner	44.0 mm (1.732 in.) 14.0 mm (0.551 in.)	Yellow
C-3 Outer	73.35 mm (2.888 in.) 19.90 mm (0.784 in.)	Red

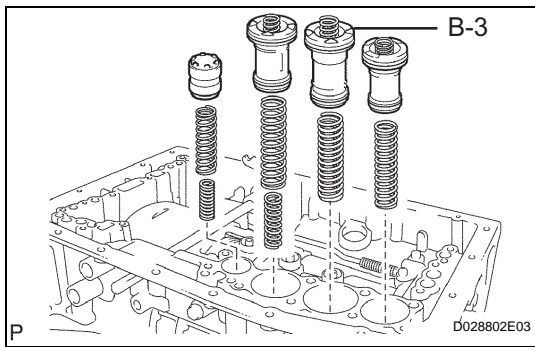

41. INSTALL B-3 ACCUMULATOR PISTON

- (a) Coat 2 new O-rings with ATF, and install them onto the piston.

- (b) Install the spring and accumulator piston into the hole.

Accumulator spring

Spring	Free length Outer diameter	Color
B-3	70.5 mm (2.776 in.) 19.7 mm (0.776 in.)	Purple

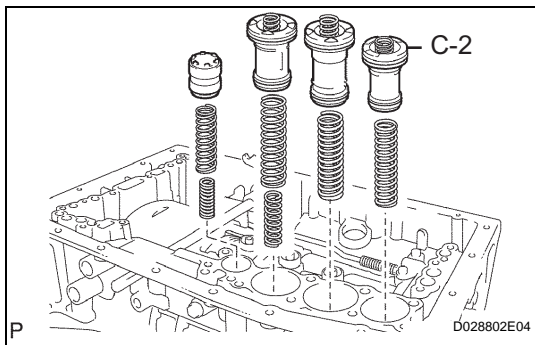
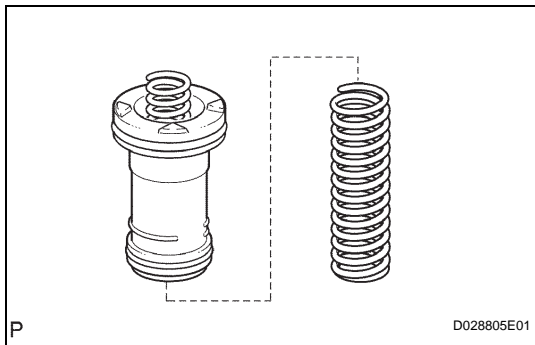

42. INSTALL C-2 ACCUMULATOR PISTON

- (a) Coat 2 new O-rings with ATF, and install them onto the piston.

- (b) Install the spring and accumulator piston into the hole.

Accumulator spring

Spring	Free length Outer diameter	Color
C-2	62.0 mm (2.441 in.) 15.9 mm (0.626 in.)	White

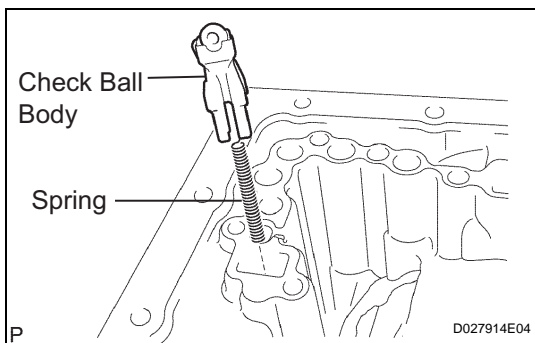
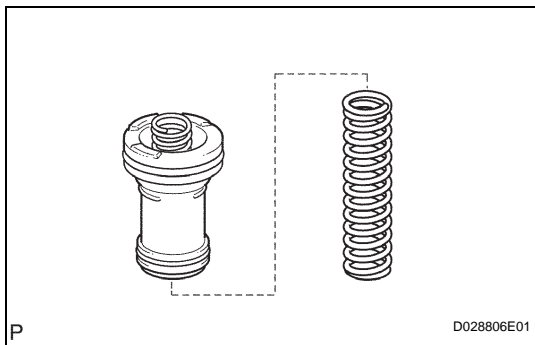

43. INSTALL CHECK BALL BODY

- (a) Install the check ball body and the spring.

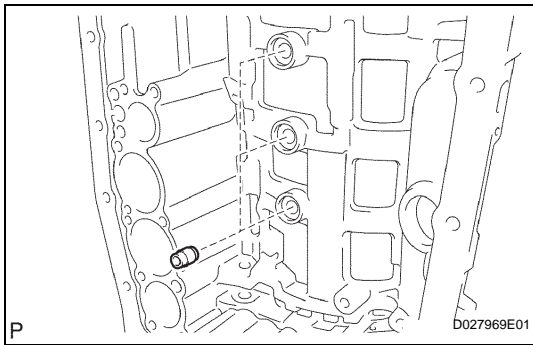
**44. INSTALL BRAKE DRUM GASKET**

- (a) Install the 3 brake drum gaskets.

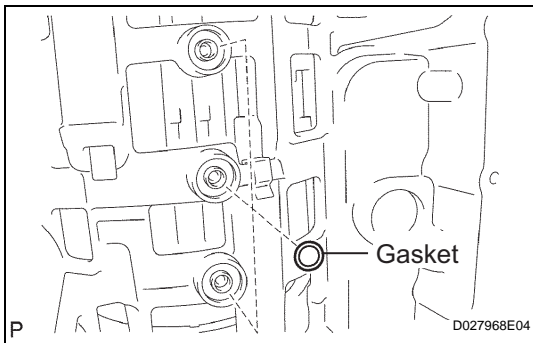
**45. INSTALL TRANSAXLE CASE GASKET**

- (a) Install the 3 transaxle case gaskets.

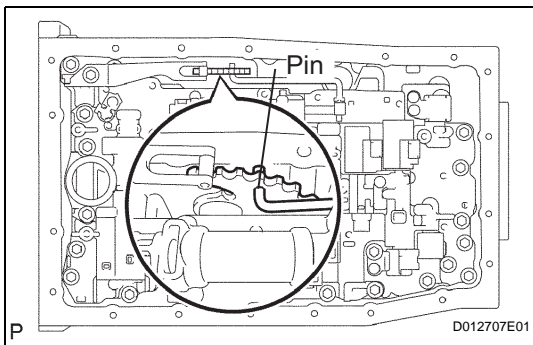
**46. INSTALL TRANSMISSION VALVE BODY ASSEMBLY**

- (a) Align the groove of the manual valve with the pin of the lever.

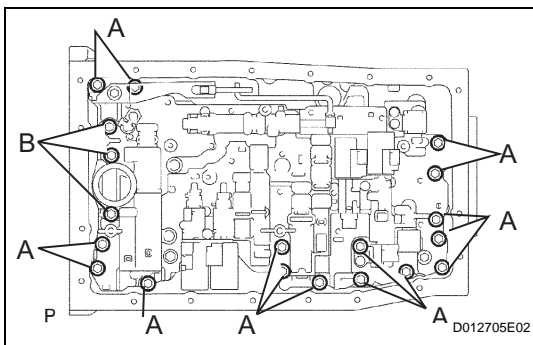

- (b) Install the 19 bolts.

Torque: 11 N*m (112 kgf*cm, 8 ft.*lbf)

HINT:

- Each bolt length is as indicated below.
- Bolt length:
25 mm (0.98 in.) for bolt A
36 mm (1.42 in.) for bolt B

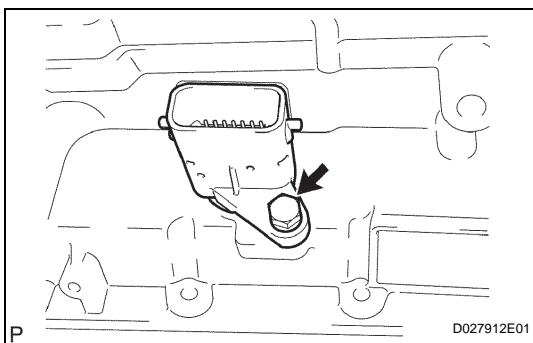
**47. INSTALL TRANSMISSION WIRE**

- (a) Install a new O-ring onto the transmission wire.
 (b) Install the transmission wire harness.
 (c) Install the bolt.
Torque: 5.4 N*m (55 kgf*cm, 48 in.*lbf)
 (d) Connect the solenoid connector.

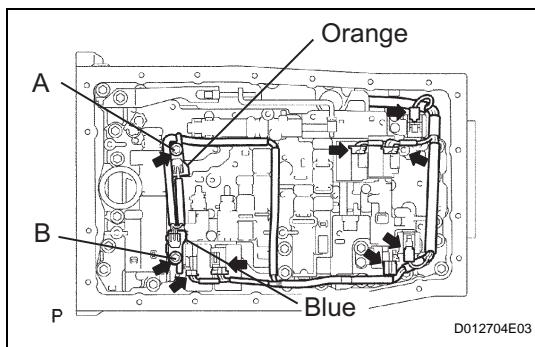

- (e) Connect the 7 solenoid connectors.
- (f) Install the ATF temperature sensor.
- (g) Install the 2 clamps and the 2 bolts.

Torque: 10 N*m (100 kgf*cm, 7 ft.*lbf) for bolt A
11 N*m (112 kgf*cm, 8 ft.*lbf) for bolt B

HINT:

- Each bolt length is as indicated below.
- Bolt length:
 12 mm (0.47 in.) for bolt A
 36 mm (1.42 in.) for bolt B

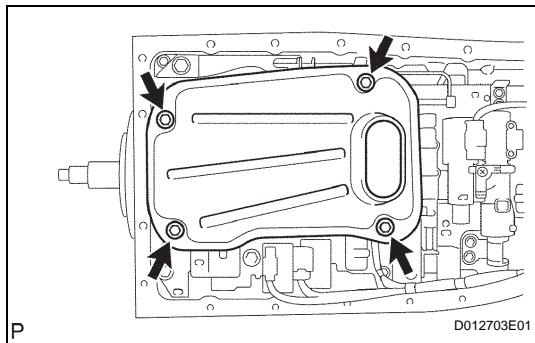

48. INSTALL VALVE BODY OIL STRAINER ASSEMBLY

- (a) Coat a new O-ring with ATF, and install them onto the valve body oil strainer assembly.
- (b) Install the oil strainer with the 4 bolts.

Torque: 10 N*m (100 kgf*cm, 7 ft.*lbf)

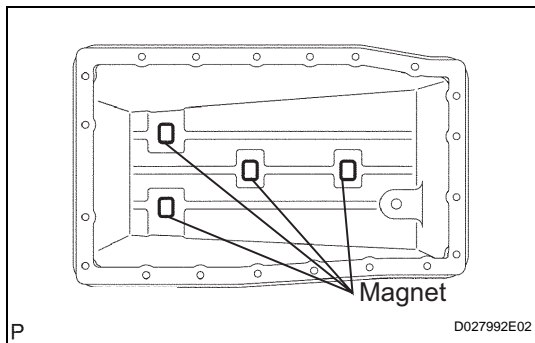

49. INSTALL TRANSMISSION OIL CLEANER MAGNET

- (a) Install the 4 transmission oil cleaner magnets.

50. INSTALL AUTOMATIC TRANSMISSION OIL PAN SUB-ASSEMBLY

- (a) Install a new gasket onto the oil pan.
- (b) Install the 20 bolts.

Torque: 4.4 N*m (45 kgf*cm, 39 in.*lbf)

- (c) Install the drain plug.

Torque: 28 N*m (285 kgf*cm, 21 ft.*lbf)

AT

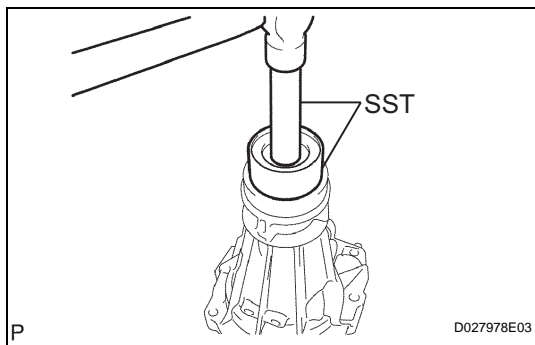

51. INSTALL AUTOMATIC TRANSMISSION EXTENSION HOUSING OIL SEAL

- (a) Using SST and a hammer, tap in a new oil seal.

SST 09710-30050, 09950-70010 (09951-07100)

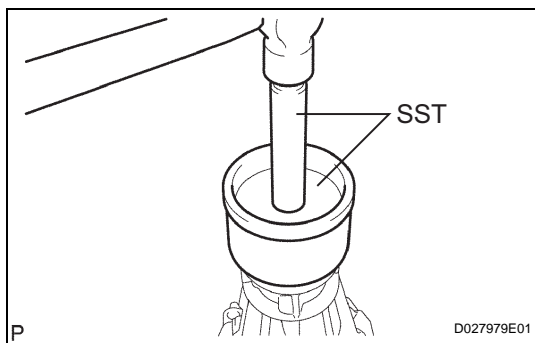

52. INSTALL EXTENSION HOUSING DUST DEFLECTOR

- (a) Using SST and a hammer, tap in a new extension housing dust deflector.

SST 09223-15020, 09950-70010 (09951-07100)

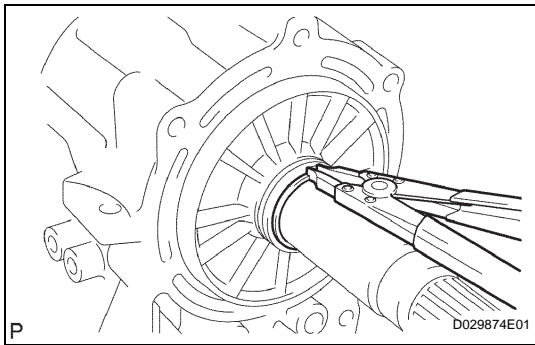

53. INSTALL EXTENSION HOUSING SUB-ASSEMBLY

- (a) Install the thrust needle roller bearing and the 2 bearing races.
- (b) Using a snap ring expander, install the snap ring.

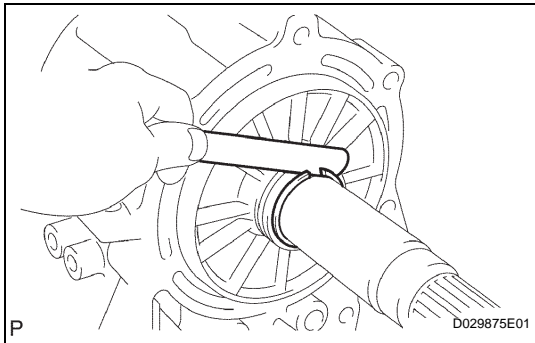

- (c) Using a feeler gauge, measure the clearance between the snap ring and the race.

Clearance:

0.05 to 0.33 mm (0.002 to 0.013 in.)

If the Clearance is still standard, select another race.

HINT:

There are 6 different thickness for the race.

Race thickness

No.	Thickness	No.	Thickness
1	3.7 mm (0.146 in.)	4	4.0 mm (0.158 in.)
2	3.8 mm (0.150 in.)	5	4.1 mm (0.161 in.)
3	3.9 mm (0.154 in.)	6	4.2 mm (0.165 in.)

- (d) Install the gasket to the extension housing.

HINT:

Take care not to drop the gasket.

- (e) Clean the threads of the bolts and the case with white gasoline.

- (f) Apply FIPG to the extension housing.

FIPG:

Toyota Genuine Seal Packing 1281, Three Bond 1281 or Equivalent

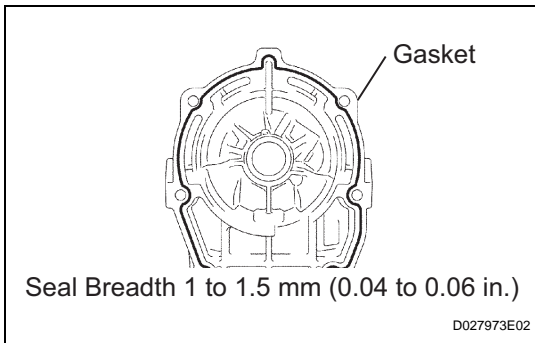

- (g) Install the extension housing with 6 bolts.

Torque: 34 N*m (345 kgf*cm, 25 ft.*lbf)

HINT:

- Each bolt length is indicated below.
- Bolt length:
 - 45 mm (1.722 in.) for bolt A
 - 35 mm (1.378 in.) for bolt B

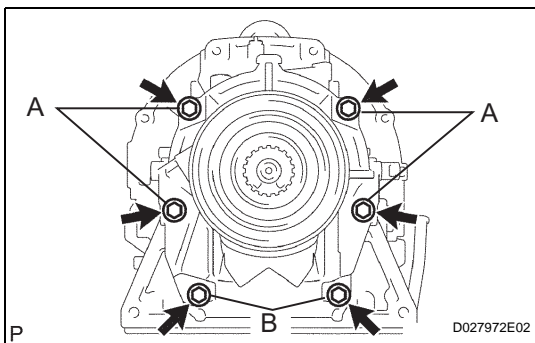

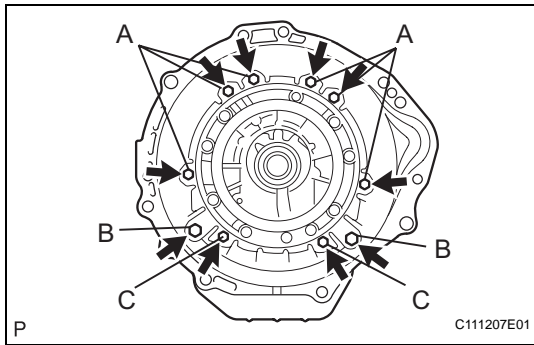
**54. INSTALL AUTOMATIC TRANSMISSION HOUSING**

- Clean the threads of the bolts and the case with white gasoline.
- Install the transmission housing with the 10 bolts.
Torque: 34 N*m (345 kgf*cm, 25 ft.*lbf) for bolt A
57 N*m (581 kgf*cm, 42 ft.*lbf) for bolt B
34 N*m (345 kgf*cm, 25 ft.*lbf) for bolt C

HINT:

- Each bolt length is indicated below.
- Bolt length:
 Bolt A: 14 mm
 Bolt B: 17 mm
 Bolt C: 14 mm

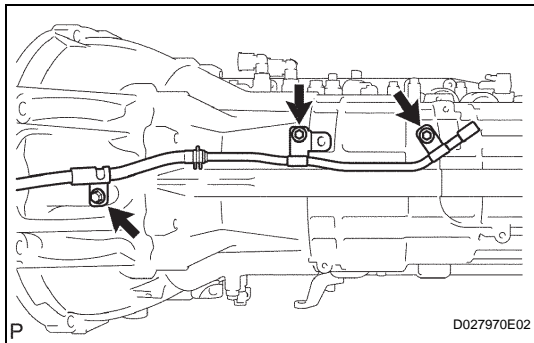
**55. INSTALL AUTOMATIC TRANSAXLE BREATHER TUBE**

- Install a new O-ring onto the breather tube.
- Install the breather tube with the 3 bolts.
Torque: 5.4 N*m (55 kgf*cm, 48 in.*lbf)

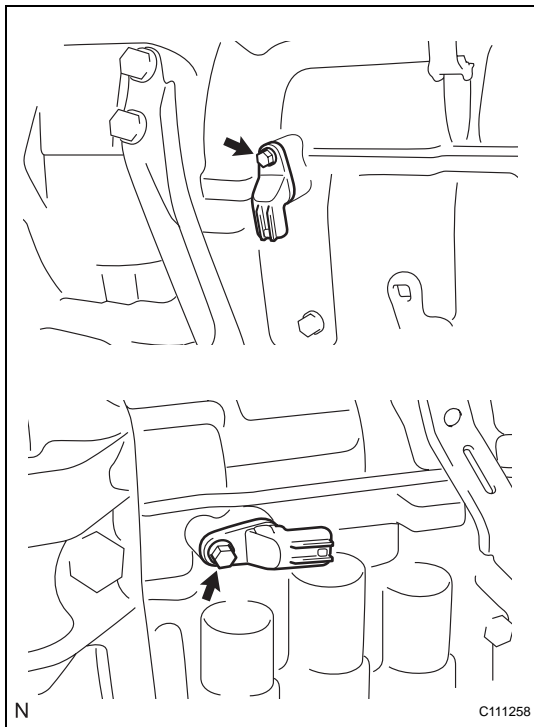
**56. INSTALL TRANSMISSION REVOLUTION SENSOR**

- Coat 2 new O-rings with AFT, and install one onto each transmission revolution sensor.
- Install the 2 transmission revolution sensors.
- Install the 2 bolts.
Torque: 5.4 N*m (55 kgf*cm, 48 in.*lbf)

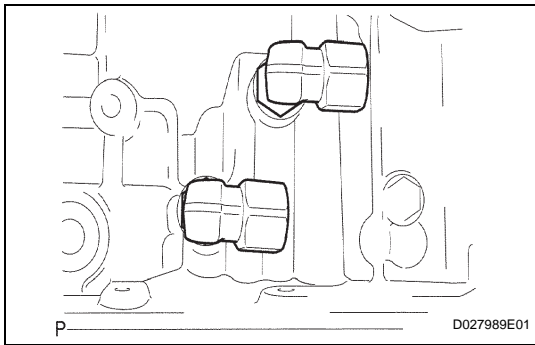
**57. INSTALL OIL COOLER TUBE UNION**

- (a) Coat 2 new O-rings with ATF, and install one onto each oil cooler tube union.
- (b) Install the 2 oil cooler tube unions.
Torque: 29 N*m (296 kgf*cm, 21 ft.*lbf)

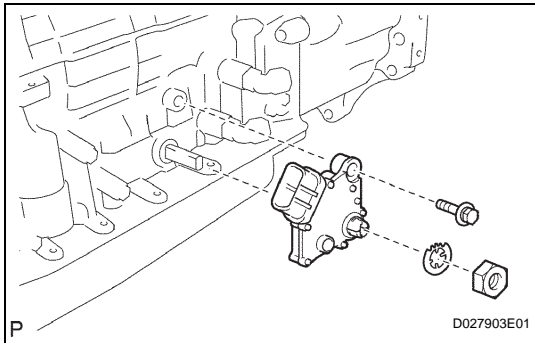
**58. INSTALL PARK/NEUTRAL POSITION SWITCH ASSEMBLY**

- (a) Install the park/neutral position switch onto the manual valve lever shaft, and temporarily install the adjusting bolt.
- (b) Install a new lock washer and the nut.
Torque: 6.9 N*m (70 kgf*cm, 61 in.*lbf)

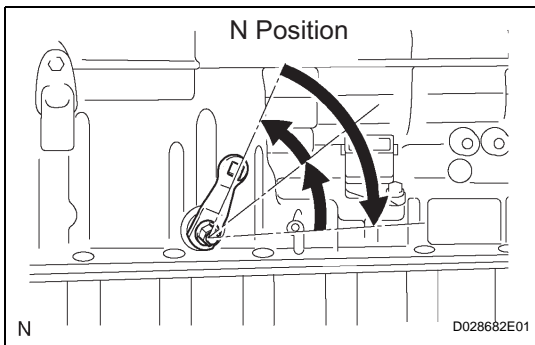

- (c) Push the control shaft rearward as much as possible.
- (d) Return the control shaft lever 2 notches to the N position.

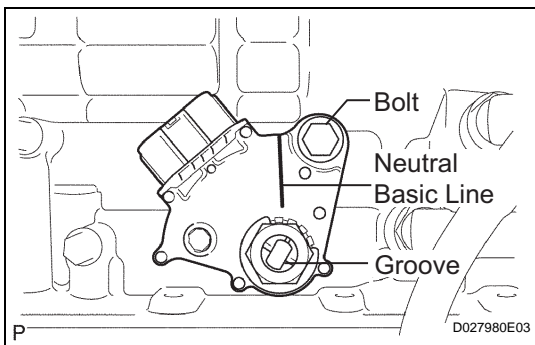

- (e) Align the neutral basic line with the switch groove as shown in the illustration, and tighten the adjusting bolt.

Torque: 13 N*m (129 kgf*cm, 9.4 ft.*lbf)

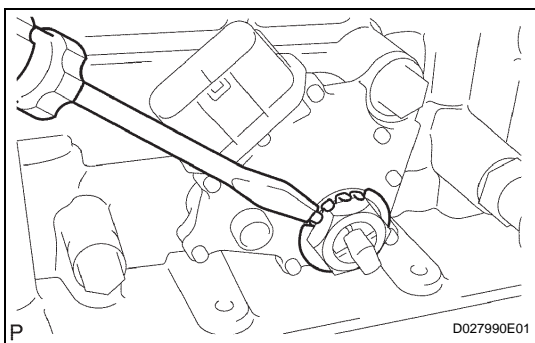

- (f) Using a screwdriver, bend the tabs of the lock washer.
HINT:
Bend at least 2 of the lock washer tabs.

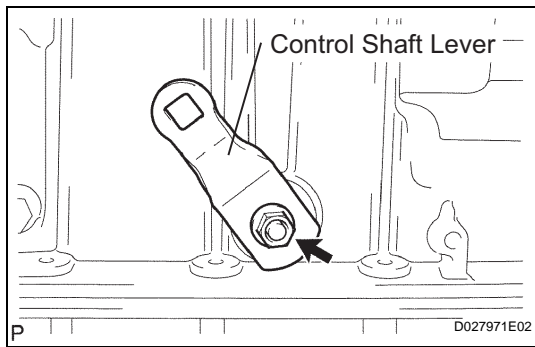
**59. INSTALL TRANSMISSION CONTROL SHAFT LEVER LH**

- (a) Install the control shaft lever LH with the washer and nut.

Torque: 16 N*m (163 kgf*cm, 12 ft.*lbf)